



523 James Street, Delhi, Ontario, Canada N4B 2Z3
 Tel #: 519-582-2440, Fax #: 519-582-0581
 Internet: www.delhi-industries.com

MODEL - DDA

Direct drive tube axial fan c/w cast aluminum propeller

All dimensions are in inches.

MODEL #	A	B	C	D
DDA12	15 $\frac{3}{8}$	14	12	17
DDA15	18 $\frac{3}{8}$	17	15 $\frac{3}{8}$	17
DDA18	21 $\frac{3}{8}$	20	18 $\frac{3}{8}$	18
DDA24	27 $\frac{3}{8}$	25 $\frac{3}{8}$	24 $\frac{3}{8}$	21
DDA30	33 $\frac{3}{8}$	32 $\frac{3}{8}$	30 $\frac{3}{8}$	21
DDA34	37 $\frac{3}{8}$	36 $\frac{3}{8}$	34 $\frac{3}{8}$	27
DDA36	39 $\frac{3}{8}$	38 $\frac{3}{8}$	36 $\frac{3}{8}$	27
DDA42	45 $\frac{3}{8}$	44 $\frac{3}{8}$	42 $\frac{3}{8}$	27*
DDA48	51 $\frac{3}{8}$	50 $\frac{3}{8}$	48 $\frac{3}{8}$	31*

* For 10 H.P. and up, dimension "D" should be 32"

Standard Features

- Cast aluminum propeller
- Heavy duty painted steel housing
- TEFC motors
- Factory assembled

Accessories

- A - Disconnect switch
- B - Inlet / outlet guards
- C - Companion rings
- D - Support clips
- E - Support legs
- F - Inspection door
- G - Electrical junction box
- H - Specials

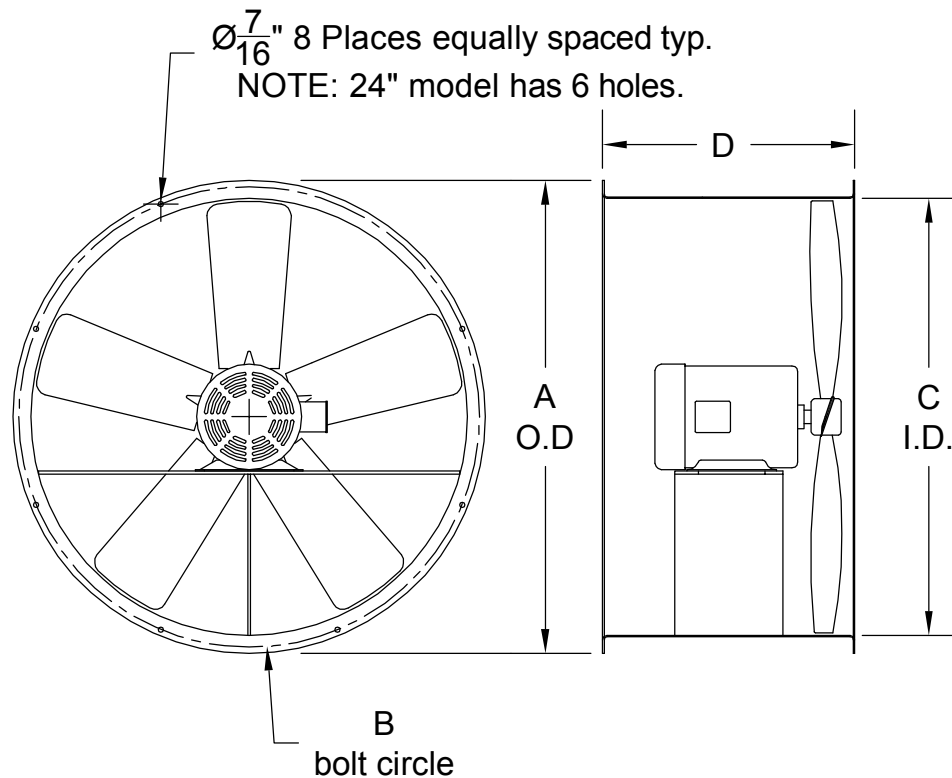

See our web site at www.delhi-industries.com or contact our factory for all current submittal drawings. Delhi Industries will not be responsible for fabrication changes or errors resulting from customer use of a non-current submittal drawing.

		FAN DATA				MOTOR DATA						ACCESSORIES & REMARKS
FAN NO.	QTY.	MODEL NO.	CFM	SP	RPM	HP	RPM	VOLTS	PH	HZ	ENCLOSURE	

PROJECT _____ ENGINEER _____ SUBMITTED BY _____ DATE _____
 LOCATION _____ CONTRACTOR _____ APPROVED BY _____ DATE _____
 FORM NO. _____ REVISION DATE _____